

PRODUCT DATA SHEET

Part Number 279319

EAN

Manufacturer Walther-Werke

WEEE-Reg-Nr: DE 22131895

100-A IEC 60309 PLUG, 1-PH, 3 Wire

- High impact thermoplastic housing featuring high resistance And toughness creating an abrasion-resistant material
- Cable gland with “onion ring” neoprene bushing
- Retaining device
- Internal strain relief with “swing-away” feature
- Locking ring and gasket
- Zinc electroplated steel screws
- Shrouded pins
- Color coded by voltage
- Double terminal screws on all amperage devices
- Ground first to mate – last to break for added safety
- Walther can produce and supply the mating cable assemblies.



Ordering/Logistics Information

Order Unit	Piece
Customs Number	
Net Weight	2.67 lbs or 1.21 kg
Packing Quantity (VPE)	2
Packaging Length	12.21 in or 0.31 m
Packaging Width	10.04 in or 0.255 m
Packaging Depth	5.91 in or 0.15 m
Gross Weight (VPE)	5.76 lbs or 2.61 kg

Conformities

CE Conformity	
RoHS directive	2011/65/EU
RoHS directive	2015/863/EU
REACH regulation	1907/2006

Certification

VDE certification	123027
UL certification	E329476 
And multiple international certifications	

Technical Product Data

IEC-amperage	125 A
Amperage according to UL/CSA (for UL-version)	100 A
Number of poles and wires	2P+G
Voltage according to EN 60309-2	480 V (50+60Hz) red
Clock hour position	7 h
Identification color	Red
Conductor cross-section	6 – 1 AWG or 16 - 50 mm ²
Cable diameter	0.94 – 1.78 in or 24 - 45 mm
Cable strip length	3.15 in +/- 0.2 in or 80 mm +/- 5 mm
Cable ferrules length	1.06 in +/- 0.04 in or 27 mm +/- 1 mm
Maximum torque terminal screw	3.5-4 Nm
Maximum torque back shell	2 Nm
Degree of protection (IP)	IP67
Connection system	Screwed terminal
Contact material	Nickel-plated brass
Cable entry	Swivel
Angle of plug	Straight
Material	Plastic
Inflammability class of insulation material according to with UL94	V2

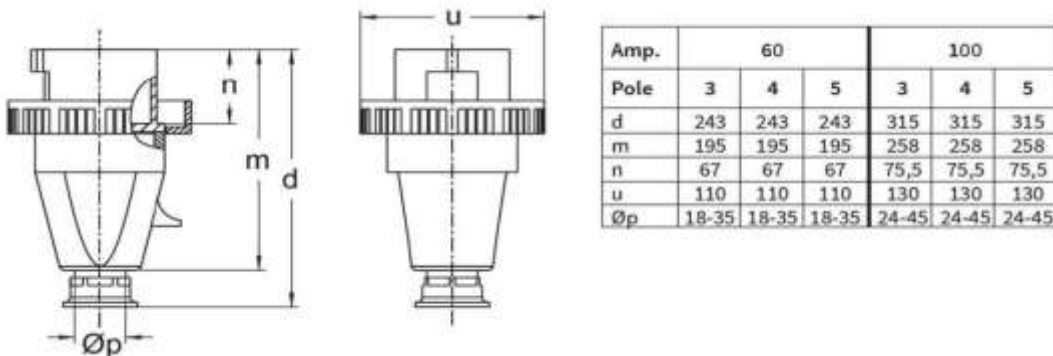

All specifications are subject to change without notice. Consult a Walthers Electric Engineer for the latest specifications or speak with a member of our Customer Care Team +1 (800) 925-8437.